



Part of GE's Sensing & Inspection Technologies business

RHM 20

Medium sized Coriolis Mass Flowmeter

The RHM 20 can measure flow rates up to 300 kg/min (660 lb/min) with temperatures in excess of 350°C and pressures up to 340 bar. This model is medium sized with true reliability for a versatile solution manufactured by Rheonik, the mass flowmeter experts.

Applications

Suitable for virtually any mass flow applications, such as:

- General flow control
- Batching
- Injections
- Dosing
- Filling

Features

The outstanding features include:

- Suitable for pressure up to 350 bar
- Typical measuring ranges from 3 kg/min to 300 kg/min
- Minimal flows as low as 2.25 kg/min
- Flow Accuracy of 0.1%
- Repeatability better than 0.05%
- Optimised solutions for your batching operation
- Extra compact design with minimal space requirement



- EEx Approvals (i.e. ATEX, CSA, ...)
- Custody Transfer Approvals (i.e. PTB, NMI, ...)

Advantages

- No pressure effect – no deterioration of accuracy due to pressure changes by the patented Omega Shape
- Patented torsion swinger design assures longest life time and increased safety (low stress in welds and increased wall thickness against abrasion)
- No moving parts – practically no maintenance
- Removable connection block



General

Owing to its typical flow range (up to 300 kg/min) and wide number of variants, the RHM 20 is suitable for many applications.

As with all other Rheonik meters, this model is based on the patented Omega tube design with increased signal to noise ratio.

This unique design, which offers excellent performance and reliability, has created the most satisfied customers worldwide. Unlike other mass flowmeter manufacturers, Rheonik uses a patented torsion rod swinger with the Omega shape and support bars which results in high accuracy measurement, which is independent of pressure, even at very low flow velocities. The meter has also extremely good repeatability and high stability for critical applications.

RHM 20 Specifications

Performance RHM 20

Max Flow 300 kg/min (660 lb/min)

Standard Models			
Rates/turndown ratio	in (kg/min)	in (lb/min)	error in % of reading
nominal rate Q_{nom}	300.00	660.40	0.20
$0.2 * Q_{max}$ (5:1)	60.00	132.30	0.20
$0.1 * Q_{max}$ (10:1)	30.00	66.15	0.20
$0.05 * Q_{max}$ (20:1)	15.00	33.08	0.20
$0.02 * Q_{max}$ (50:1)	6.00	13.20	0.50

Typical ΔP in bar (psi)		
1 cP	100 cP	1000 cP
0.7 (10.3)	1.3 (18.2)	10.5 (150)
~ 0.1 (0.5)	0.2 (3.1)	2.0 (29)
~ 0 (0.2)	0.1 (1.5)	1.0 (15)
~ 0 (0)	~ 0 (0.8)	0.5 (7)
~ 0 (0)	~ 0 (0.3)	0.2 (3)

Optimized Low Flow Models ^(*) /optimized to be operated between $0.015 * Q_{max}$ and $0.3 * Q_{max}$			
Rates/turndown ratio	in (kg/min)	in (lb/min)	error in % of reading
$0.3 * Q_{max}$ (1:1)	90.00	198.40	0.15
$0.02 * Q_{max}$ (15:1)	6.00	13.20	0.20
$0.015 * Q_{max}$ (20:1)	4.50	9.90	~ 0.50 ^(**)

~ 0.1 (1.1)	0.3 (4.7)	3.1 (44)
~ 0 (0)	~ 0 (0.3)	0.2 (3)
~ 0 (0)	~ 0 (0.2)	0.1 (2)

^(*) serial/single path version offers the same accuracy at half the flow ($Q_{max} = 100 \text{ kg/min}$)

^(**) around 0.30 - 0.70 % accuracy depending on the installation conditions

Gold Line Models/application fine tuned meters			
Rates/turndown ratio	in (kg/min)	in (lb/min)	error in % of reading
$1 * Q_{nom}$ (1:1)	300.00	660.40	0.10
$0.1 * Q_{nom}$ (10:1)	30.00	66.15	0.12
$0.05 * Q_{nom}$ (20:1)	15.00	33.08	0.15

0.7 (10.3)	1.3 (18.2)	10.5 (150)
~ 0 (0.2)	~ 0.1 (1.5)	1.0 (15)
~ 0 (0)	~ 0 (0.8)	0.5 (7)

Repeatability

better ± 0.05 % of rate

Density

better than $\pm 0.0025 \text{ g/cc}$ - Gold Line: Field adjustable to better $\pm 0.001 \text{ g/cc}$

Temperature

Better $\pm 1^\circ\text{C}$

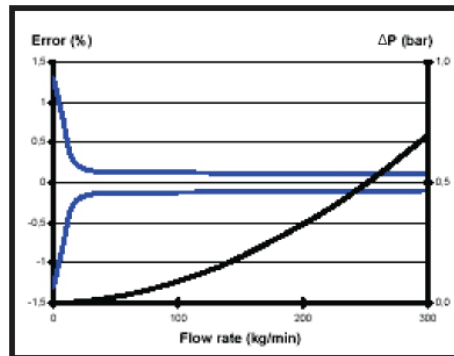
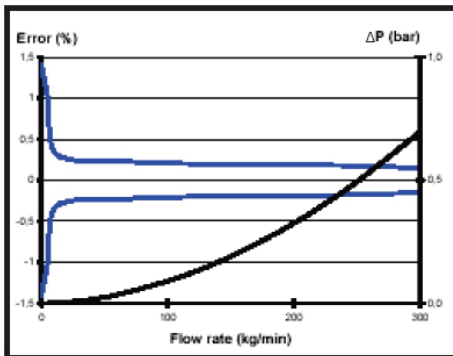

Standard Models

Gold Line Models

For serial (single pipe/path) sanitary design Q_{max} is 150 kg/min (50%). Data above refer to standard wall thickness.

Error of reading (including zero drift) indications refer to reference conditions H_2O , 18-24°C (66-76°F), 1-3 bar (15-45 psi).

RHM sensor do not suffer from pressure effect due to torsional oscillation and semi circle (non-deforming) measurement section.

Temperature changes of $\pm 25^\circ\text{C}$ around the operating point are negligible.

Pressure drop refers to Newton liquids, with parallel measuring loops and block/manifold connection.

Nominal flow refers to approx. 10 m/s (33 ft/sec) velocity in measuring loops for best performance.

Calibration to customer range, with increased accuracy, possible.

General Outline Dimensions RHM 20

Type I (w/removable manifold block - serial [SM0]/parallel [PM0]/PTFE seals)

Thread Type:

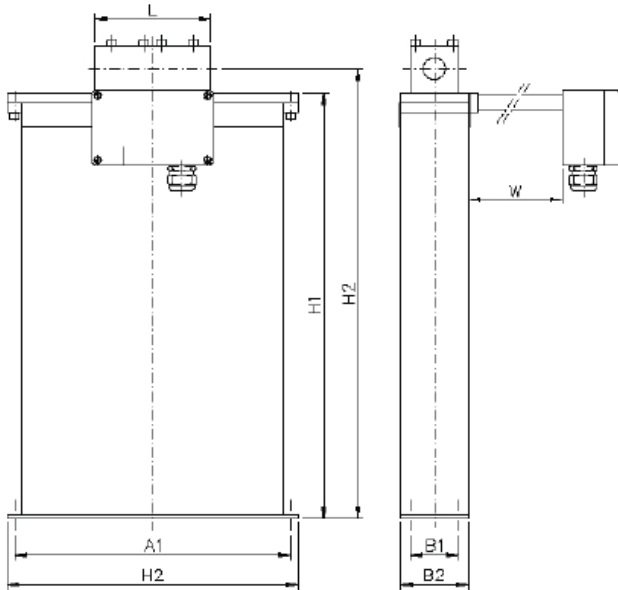

Weight approx. 16 kg (35 lb)

A1=285 mm (11.22 in) B1=50 mm (1.97 in) H1=454 mm (17.87 in)
 A2=300 mm (11.81 in) B2=70 mm (2.76 in) H2=480 mm (18.90 in)

W = 0 mm for standard temperature models -45/-20°C to 120°C (-49/-4°F to 248°F)
 and W = 150 mm (5.91 in) for extended (ET1, ET2) and high temperature models(*)

Flange Type:

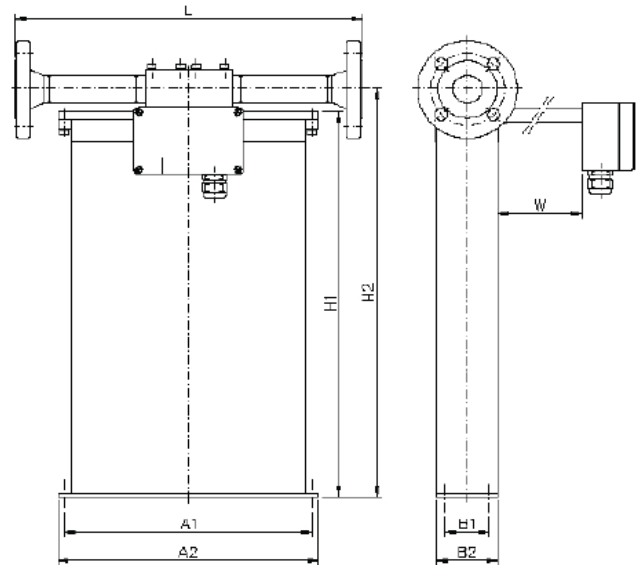

Weight approx. 23 kg (51 lb)

Process Connection	Face to Face Length (L) (**)	Order Code
Thread Standard	G 1 in female	136 mm (5.35 in) G1
	NPT 1 in female	136 mm (5.35 in) N1
Flange Standard	2 in CL 150 acc. ANSI B16.5	460 mm (18.11 in) A1
	2 in CL 300 acc. ANSI B16.5	460 mm (18.11 in) A2
	2 in CL 600 acc. ANSI B16.5	500 mm (19.68 in) A3
	DN50/PN40 acc. DIN 2635 - C	460 mm (18.11 in) D1
	DN50/PN100 acc. DIN 2637 - E	500 mm (19.68 in) D2
Flange Optional	2 in CL 900/1500 acc. ANSI B16.5	500 mm (19.68 in) A5
	DN50/PN160 acc. DIN 2638 - E	500 mm (19.68 in) D3
Special	Different sized flanges	please consult factory XX

(*) For high temperature models (HT) Type II or Type III preferred - see next pages.
 (**) Customization possible on request.

Our standard seals are PTFE - Manifold block on request available without seals but with brazed connection block.

The finish type of our ANSI flanges is RF/SF (AARH 125-250 (µ in) - Ra 3,2 up to 6,3 (µm)). Others available on request.

Above table only shows our general process fittings.
 For further customization with regard to face to face length and special fittings please contact your local agent.

General Outline Dimensions RHM 20

Type II (sealless welded, parallel measuring loops w/o seals [PF_])

Flange Type:

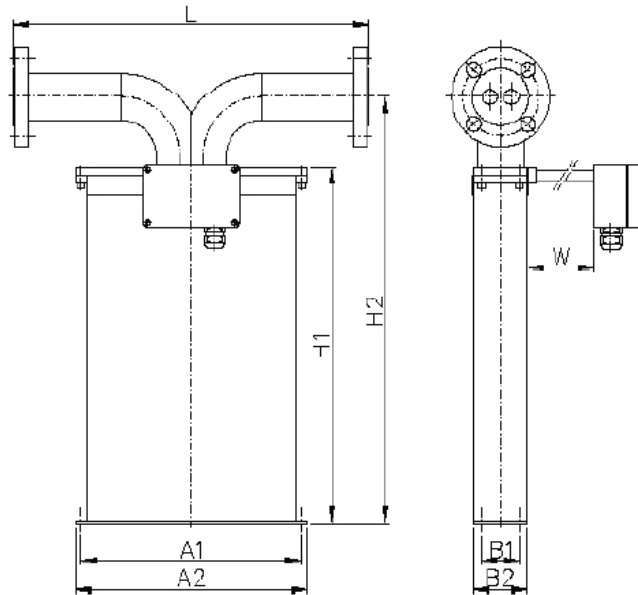

Weight approx. 23 kg (51 lb)

A1=285 mm (11.22 in) B1=50 mm (1.97 in) H1=454 mm (17.87 in)
 A2=300 mm (11.81 in) B2=70 mm (2.76 in) H2=540 mm (21.25 in)

W = 0 mm for standard temperature models -45/-20°C to 120°C (-49/-4°F to 248°F)
 and W = 150 mm (5.91 in) for extended (ET1, ET2) and high temperature models

Special Fittings:

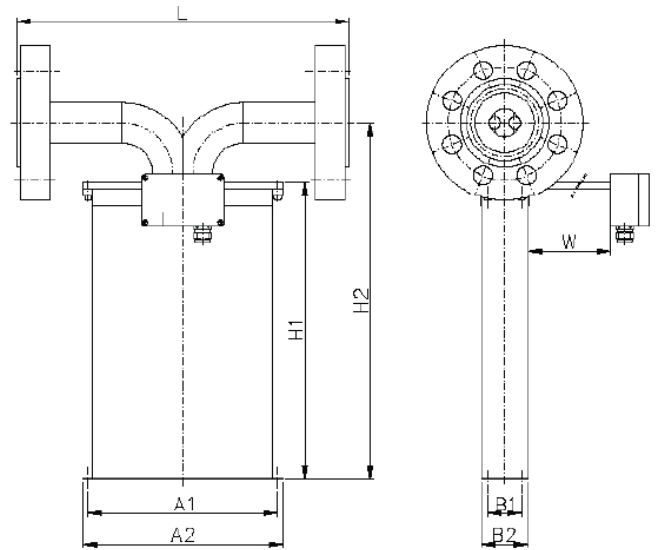

Weight approx. 23 kg (51 lb)

Process Connection	Face to Face Length (L) (")	Order Code
Standard	2 in CL 150 acc. ANSI B16.5	460 mm (18.11 in) A1
	2 in CL 300 acc. ANSI B16.5	460 mm (18.11 in) A2
	2 in CL 600 acc. ANSI B16.5	500 mm (19.68 in) A3
	DN50/PN40 acc. DIN 2527 - C	460 mm (18.11 in) D1
	DN50/PN100 acc. DIN 2527 - E	500 mm (19.68 in) D2
Optional	2 in CL 900/1500 acc. ANSI B16.5	500 mm (19.68 in) A5
	2 in CL 2500 acc. ANSI B16.5	500 mm (19.68 in) A8
	DN50/PN160 acc. DIN 2527 - E	500 mm (19.68 in) D3
Special	G 1 in female	400 mm (15.75 in) G1
	NPT 1 in female	400 mm (15.75 in) N1
	Swagelok 1 in tube inlet (SS-1610-1-16W)	560 mm (22.05 in) W1
	DN40/PN250 acc. DIN 2527 - E	500 mm (19.68 in) XX
	Different sized flanges	please consult factory XX

(*) Customization possible on request.

The finish type of our ANSI flanges is RF/SF (AARH 125-250 (µinch) - Ra 3,2 up to 6,3 (µm)). Others available on request.

Above table only shows our general process fittings.

For further customization with regard to special fittings and face to face length please contact your local agent.

General Outline Dimensions RHM 20

Type III (sealless welded, serial measuring loops - single path w/o seals [SF0])

Sanitary Fittings:

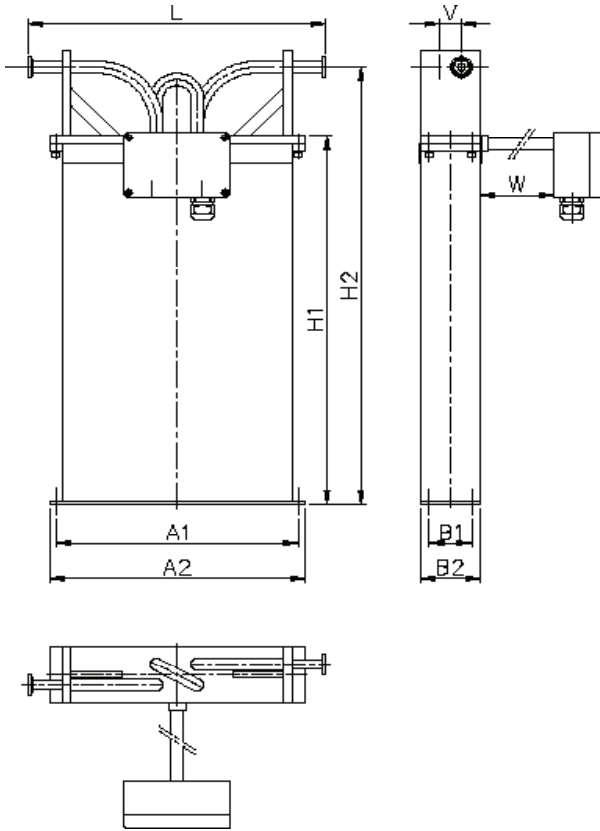

Flange/Other Fittings:

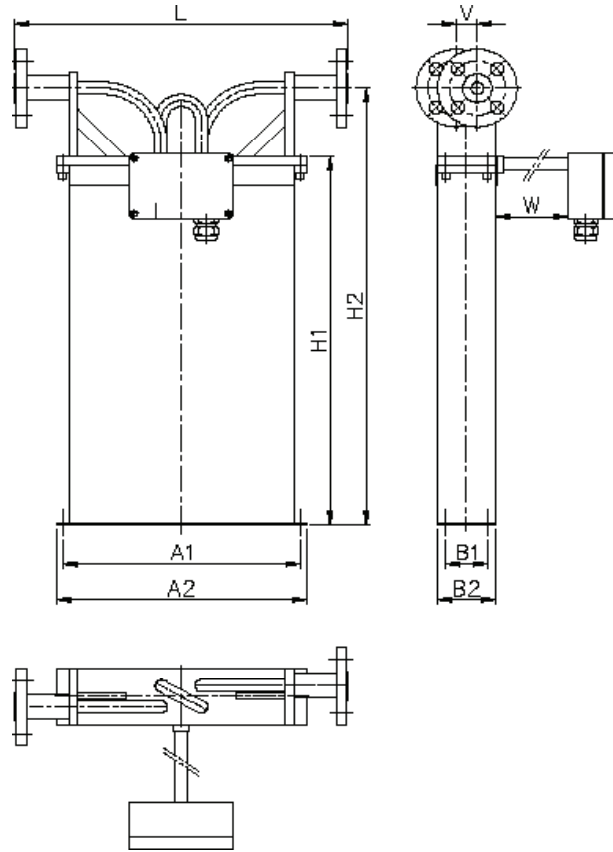

A1=285 mm (11.22 in) B1=50 mm (1.97 in) H1=454 mm (17.87 in)
 A2=300 mm (11.81 in) B2=70 mm (2.76 in) H2=540 mm (21.25 in)
 V=26 mm (1.02 in)

W = 0 mm for standard temperature models -45/-20°C to 120°C (-49/-4°F to 248°F)
 and W = 150 mm (5.91 in) for extended (ET1, ET2) and high temperature models

Process Connection	Face to Face Length (L) (*)	Order Code
Sanitary Fittings (**)	1 in Tri Clamp acc. DIN 32676	350 mm (13.78 in) S0
	DN20/Sanitary acc. DIN 11851	350 mm (13.78 in) S2
Flange Other Fittings	2 in CL 150 acc. ANSI B16.5	400 mm (15.75 in) A1
	2 in CL 300 acc. ANSI B16.5	400 mm (15.75 in) A2
	DN50/PN40 acc. DIN 2527 - C	400 mm (15.75 in) D1
	1 in or 1 ½ in CL 150 acc. ANSI B16.5	400 mm (15.75 in) XX
	1 in or 1 ½ in CL 300 acc. ANSI B16.5	400 mm (15.75 in) XX
	DN25 or DN40/PN40 acc. DIN 2527 - C	400 mm (15.75 in) XX
	Different sized flanges	please consult factory XX

(*) Customization possible on request.

(**) Fitting material is 1.4435/SS 316L (Tri Clamp acc. DIN 32676) and 1.4301/SS 304 (Sanitary connection acc. DIN 11851).

The finish type of our ANSI flanges is RF/SF (AARH 125-250 (µinch) - Ra 3,2 up to 6,3 (µm)). Others available on request.

Above table only shows our general process fittings.

For further customization with regard to special fittings and face to face length please contact your local agent.

General Specifications RHM 20

Approvals

- ATEX (CESI 02 ATEX 053 X): Ex II 1 G, EEx ia IIC T6-T1
- CSA (220705) Class I, Div 1 and 2, Groups A, B, C and D; Type 3
- Custody Transfer Approvals (PTB 1.32-97027224 and NMI TC 3382)
- PED according to directive 97/23/EC available
- 3A Sanitary Approvals

Electrical Connection

- Junction box/aluminium coated (standard) IP 65 (Nema 4X) (Junction box in SS optional)
- Cable entry M25 x 1.5 (M20 x 1.5, ½ in and ¾ in NPT optional)
- Max cable length between RHM and RHE: 100 m (330 ft) 200 m (660 ft) only with factory approval

Housing

- Stainless Steel: 1.4301/SS 304
- others on request -
- Protection class: IP 65 (Nema 4X)
- higher on request -

Material of Wetted Parts

- 1.4571/SS 316Ti (standard)
- 1.4539/SS 904L on request
- Hastelloy C22 on request
- Tantalum on request
- Other material on request

Pressure Rating

- Pressured part of the meter consists of the measuring loops and the connection part. The weaker of both parts decides the maximum allowed operating pressure. Below is the max. operating pressure of the measuring loops(*).

() These values are only valid for SS 316Ti & SS 904L materials. Statements for others materials on request.*

- **Standard Version:**

110 bar @ 120°C (1595 psi @ 248°F)

90 bar @ 210°C (1305 psi @ 410°F)

80 bar @ 350°C (1160 psi @ 662°F) wall thickness is generally 1.0 mm (0.04 in)

- **Optional high pressure version:**

225 bar @ 120°C (3260 psi @ 248°F) wall thickness is generally 2.0 mm (0.08 in)

- **Extremely high pressure version:**

- on request -

Temperature Rating

- NT Models from -20°C to 120°C (-4°F to 248°F)
- ET Models from -45°C to 120°C (-49°F to 248°F)
- ET1 Models from -200°C to 50°C (-328°F to 122°F)
- ET2 Models from -45°C to 210°C (-49°F to 410°F)
- HT Models from 0°C to 350°C (32°F to 662°F)

Order Code RHM 20

Order Code Structure

The order code of the Rheonik Sensors consists of 6 sections (see previous pages/below). Restrictions of combinations may apply. For specials, please comment your needs in plain text/sketches.

RHM 20

Temperature Rating

- T1** NT Models (Normal Temperature Models) from -20°C to 120°C (-4°F to 248°F)
- TA** ET Models (Extended Temperature Models) from -45°C to 120°C (-49°F to 248°F)
- T2** ET2 Models (Extended Temperature Models) from -45°C to 210°C (-49°F to 410°F)
- T3** ET1 Models (Extended Temperature Models) from -200°C to 50°C (-328°F to 122°F)
- T4** HT Models (High Temperature Models) from 0°C to 350°C (32°F to 662°F)

Pressure Rating

- P1** Standard pressure version (110 bar @ 120°C/1595 psi @ 248°F) - page 6 -
- P2** High pressure version (225 bar 120°C/3260 psi @ 248°F) - page 6 -
- PX** Extremely high pressure version (on request) - page 6 -

Construction Type

- PM0** Parallel Measuring Loops with removable Block/Manifold and PTFE Seals - page 3 -
- SM0** Serial Measuring Loops with removable Block/Manifold and PTFE Seals - page 3 -
- PF_** Parallel Measuring Loops Seal Less Welded Version - page 4 -
- SF0** Serial Measuring Loops Seal Less Welded Version/Single Path - page 5 -
- XXX** Other construction type on request

Material of Wetted Parts

- M1** 1.4571/SS 316Ti
- M2** 1.4539/SS 904L
- M3** Hastelloy C22
- M4** Tantalum

Process Connection

- XX** Code available on pages 3, 4 and 5.

Hazardous Area Approvals

- NN** Without Ex Approvals
- AT** ATEX Approvals (CESI 02 ATEX 053 X) - Ex II 1 G, EEx ia IIC T6-T1
- CS** CSA Approvals (220705) - Class 1, Div 1/Group A, B, C, and D; Type 3

RHM 20 [] - [] - [] - [] - [] - [] - []

Order Code Example

M#20 T1 P1 SM0 M1 N1 AT

- T1:** NT (Normal Temperature Models) from -20°C to 120°C (-49°F to 248°F)
- P1:** Standard pressure version (110 bar @ 120°C/1595 psi @ 248°F)
- SM0:** Serial Measuring Loops with removable Block/Manifold and PTFE Seals
- M1:** 1.4571/SS 316 Ti
- N1:** Female Thread NPT 1 in
- AT:** ATEX Approvals (CESI 02 ATEX 053 X)

M #20 - [] - [] - [] - [] - [] - [] - []



EX-CALIBRA

Autoryzowany dystrybutor
GE Measurement & Control Solutions

41-400 Mysłówice, ul. Portowa 25
tel.: 32 2239280, fax: 32 2239281
e-mail: ex-calibra@ex-calibra.pl
Internet: www.ex-calibra.pl

www.gesensinginspection.com

920-000-01